33275-MP

ArduCAM

ArduCAM-M-2MP Camera Shield

2MP SPI Camera Hardware Application Note

Rev 1.0, Mar 2015



33275-MP



Table of Contents

1	Introduction	2
2	Typical Wiring	2
2.1	Single Camera Wiring	2
2.2	Multi Cameras Wiring	2
3	I2C Interface	3
4	SPI Slave Interface	4
5	ArduChip Timing Diagram	4
5.1	SPI Bus Write Timing	4
5.2	SPI Bus Single Read Timing	4
5.3	SPI Bus Burst Read Timing	5
6	Registers Table	5

1 Introduction

This application note describes the detail hardware operation of ArduCAM-M-2MP camera shield.

2 Typical Wiring

2.1 Single Camera Wiring

The typical connection between ArduCAM shield and Arduino or etc platform is shown in the Figure 1. More typically the Figure 2 shows the wiring for Arduino UNO R3 board.

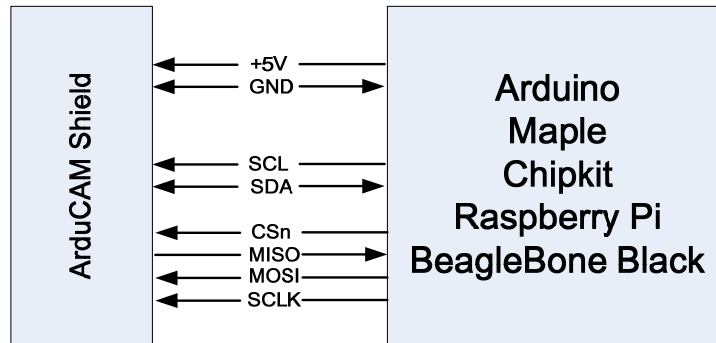

Figure 1 Typical Wiring

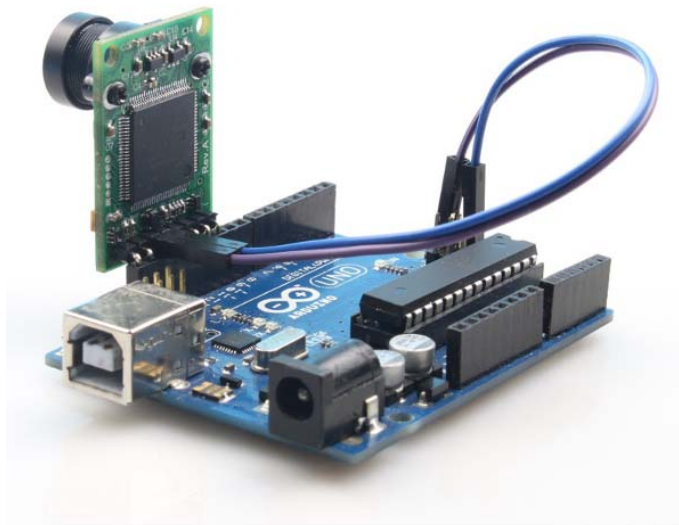

Figure 2 Wiring for Arduino UNO R3

2.2 Multi Cameras Wiring

The multi-cameras connection between ArduCAM shield and Arduino or etc platform is shown in the Figure 3. More typically the Figure 4 shows the multi-cameras wiring for Arduino UNO R3 board.

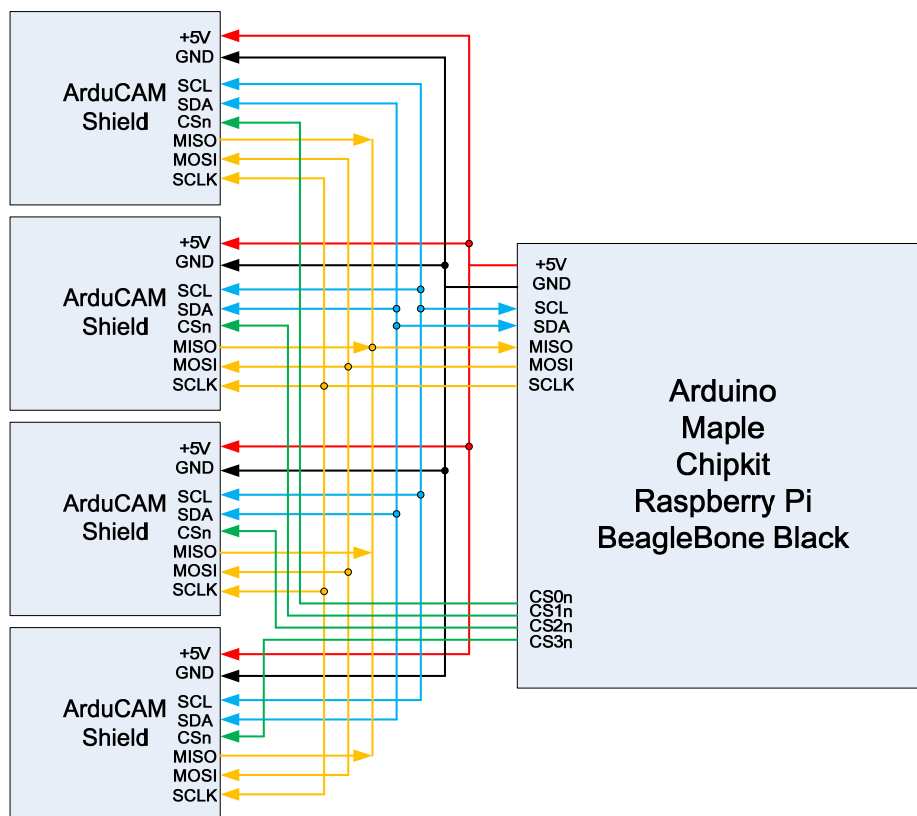

Figure 3 Multi-Cameras Wiring



Figure 4 Multi-Cameras Wiring on Arduino UNO

3 I2C Interface

The I2C interface is directly connected to the image sensor OV2640. The OV2640 I2C slave address is 0x60 for write and 0x61 for read. User can use I2C master to read and write all the registers in the OV2640 sensor. For more information about the OV2640 register, please refer the OV2640 datasheet. The Figure 5 shows writing value 0x01 to the OV2640 register 0xFF. The Figure 6 shows reading value 0x26 from the OV2640 register 0x0A.

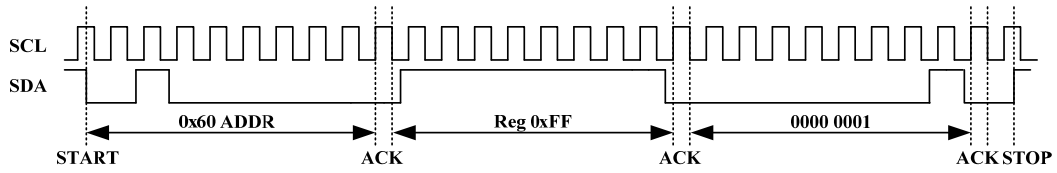

Figure 5 I2C Write Bus Timing

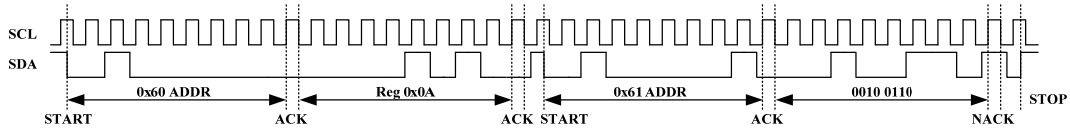

Figure 6 I2C Read Bus Timing

4 SPI Slave Interface

The ArduCAM SPI slave interface is fixed SPI mode 0 with POL = 0 and PHA = 1. The maximum speed of SCLK is designed for 8MHz, care should taken do not over clock the maximum 8MHz. The SPI protocol is designed with a command phase with variable data phase. The chip select signal should always keep asserted during the SPI read or write bus cycle.

The first bit[7] of the command phase is read/write byte, ‘0’ is for read and ‘1’ is for write, and the bit[6:0] is the address to be read or write in the data phase. ArduChip register table see Table 1.

5 ArduChip Timing Diagram

5.1 SPI Bus Write Timing

The SPI bus write timing composed of a command phase and a data phase during the assertion of the chip select signal CSn. The first 8 bits is command byte which is decoded as a register address, and the second 8 bits is data byte to be written to the ArduChip internal registers.

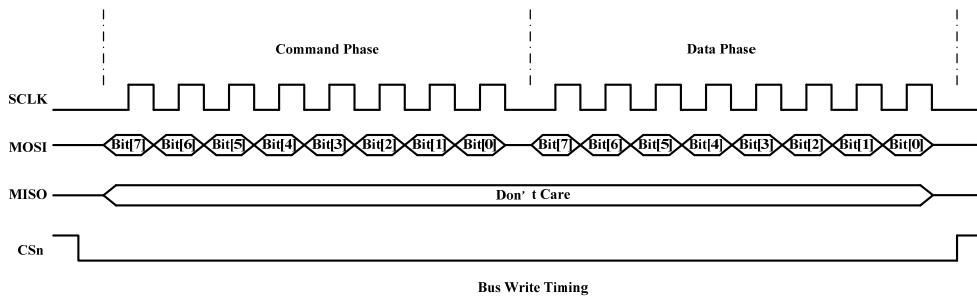

Figure 7 SPI Bus Write Timing

5.2 SPI Bus Single Read Timing

The SPI bus single read timing is for read operation of ArduChip internal registers and single FIFO read function. It is composed of a command phase and a data phase during the assertion of chip select signal CSn. The first 8 bits is command byte which is decoded as a register address, the second 8 bits is dummy byte written to the SPI bus MOSI signal, and the content read back from register is appeared on the SPI bus MISO signal.

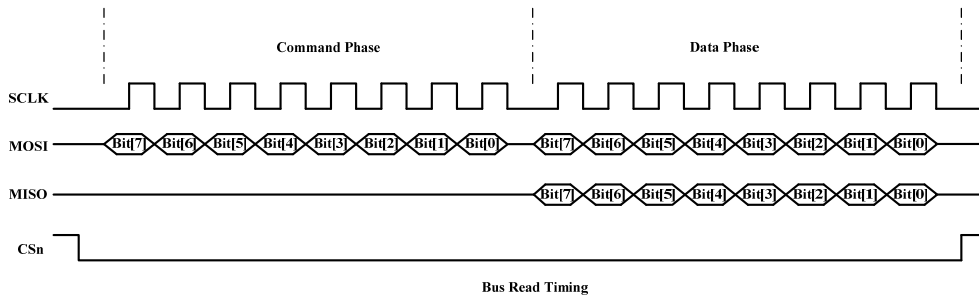

Figure 8 SPI Bus Single Read Timing

5.3 SPI Bus Burst Read Timing

The SPI bus burst read timing is only for burst FIFO read operation. It is composed of a burst read command phase and multiple data phases in order to get double throughput compared to the single FIFO read operation. The first byte read from the FIFO is a dummy byte, and the following bytes are valid bytes.

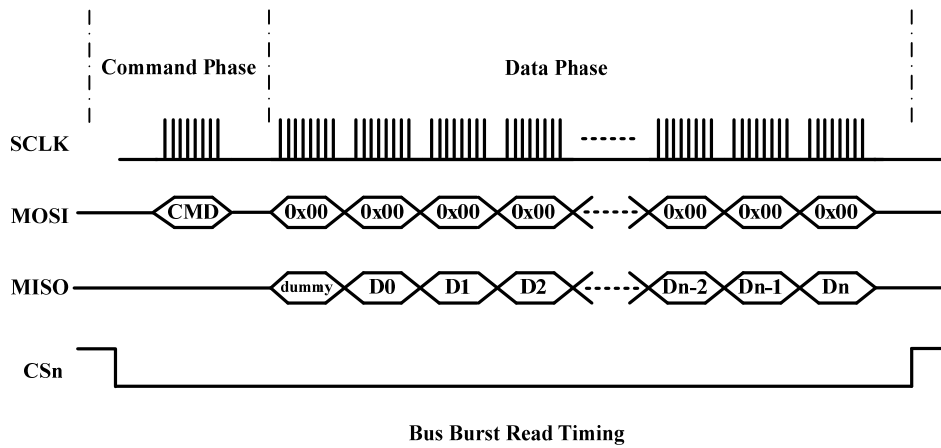

Figure 9 SPI Bus Burst Read Timing

6 Registers Table

Sensor and FIFO timing is controlled with a set of registers which is implemented in the ArduChip. User can send capture commands and read image data with a simple SPI slave interface. The detail description of registers' bits can be found in the software section in this document.

As mentioned earlier the first bit[7] of the command phase is read/write byte, '0' is for read and '1' is for write, and the bit[6:0] is the address to be read or write in the data phase. So user has to combine the 8 bits address according to the read or write commands they want to issue.

Table 1 ArduChip Register Table

Register Address bit[6:0]	Register Type	Description
0x00	RW	Test Register
0x01	RW	Capture Control Register Bit[2:0]: Number of frames to be captured
0x02	RW	Reserved
0x03	RW	Sensor Interface Timing Register Bit[0]: Sensor Hsync Polarity,

		<p>0 = active high, 1 = active low Bit[1]: Sensor Vsync Polarity 0 = active high, 1 = active low Bit[3]: Sensor data delay 0 = no delay, 1= delay 1 PCLK Bit[4]: FIFO mode control 0 = FIFO mode disable, 1 = enable FIFO mode Bit[6]: low power mode control 0 = normal mode, 1 = low power mode</p>
0x04	RW	<p>FIFO control Register Bit[0]: write '1' to clear FIFO write done flag Bit[1]: write '1' to start capture Bit[4]: write '1' to reset FIFO write pointer Bit[5]: write '1' to reset FIFO read pointer</p>
0x05	RW	<p>GPIO Direction Register Bit[0]: Sensor reset IO direction Bit[1]: Sensor power down IO direction Bit[2]: Sensor power enable IO direction 0 = input, 1 = output</p>
0x06	RW	<p>GPIO Write Register Bit[0]: Sensor reset IO value Bit[1]: Sensor power down IO value Bit[1]: Sensor power enable IO value</p>
0x3B	RO	Reserved
0x3C	RO	Burst FIFO read operation
0x3D	RO	Single FIFO read operation
0x3E	RO	Reserved
0x3F	RO	Reserved
0x40	RO	<p>ArduChip version, constant value 0x40 for 2MP model Bit[7:4]: integer part of the revision number Bit[3:0]: decimal part of the revision number</p>
0x41	RO	<p>Bit[0]: camera vsync pin status Bit[3]: camera write FIFO done flag</p>
0x42	RO	Camera write FIFO size[7:0]
0x43	RO	Camera write FIFO size[15:8]
0x44	RO	Camera write FIFO size[18:16]
0x45	RO	<p>GPIO Read Register Bit[0]: Sensor reset IO value Bit[1]: Sensor power down IO value Bit[1]: Sensor power enable IO value</p>